

## GROUNDING ESD STATIC CONTROL FLOORING

Several acceptable methods are used to ground static control flooring depending on local codes, the job conditions and the personal preference of the contractor. The three most widely used procedures are described below.

### AFFIXING THE COPPER GROUNDING STRIP TO THE FLOOR TILE OR STATIC-CONTROL FLOOR COATING.

First affix the grounding strap to the floor by laying the copper strip on the wet adhesive, at the time it is spread on the floor and extending approximately one foot out into the room perpendicular to the wall. For ESD coating installations, the strip should be glued to the bare concrete using double sided tape or generic epoxy. StaticWorx can supply special adhesive backed copper tape for grounding installations of coatings. For a tile or sheet floor installation, the strip should be covered with conductive adhesive, followed by placing the tile or sheet floor over the grounding strap. This area must be rolled when the balance of the installation is rolled with the flooring roller. Leave approximately 10 - 12 inches of the copper strip exposed. This end of the grounding strap will be attached to the designated ESD floor ground point.

## METHOD 1: GROUNDING TO A CIRCUIT GROUND

### OPTION A

The copper strip can extend up to one of the screws securing the outlet to the wall. The strip can be attached using the screw and then covered with the outlet plate.

### OPTION B

Prior to the installation of the static control flooring the electrical contractor can tie in a ground wire (#10 or #12) to a convenient ground bus or an electrical outlet. Then the wire is fed down the inside of the wall to the floor line, where the baseboard meets the floor. Bring the wire through a small hole in the drywall at the floor line. From here it can be easily attached to the floor ground. The exposed end of the copper-grounding strip is then wound together with the ground wire and tightened together with the use of a wire nut to securely hold it in place. This connection of the two leads is then pushed into the hole in the wall along with the excess wire. The baseboard or wall base can be used to cover the strip once they are applied to the wall.

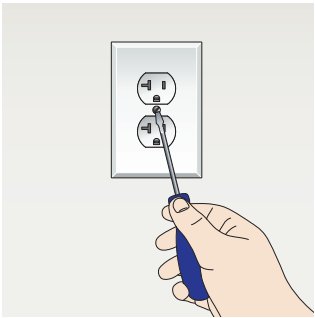

**Step 1.**

Remove center screw on cover of AC electrical outlet using a screw driver.

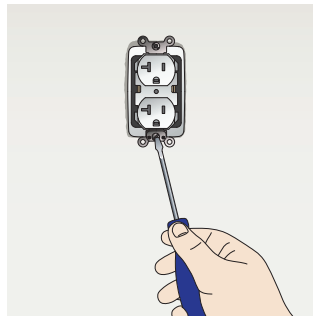

**Step 2.**

Locate and remove grounding screw inside AC electrical outlet.

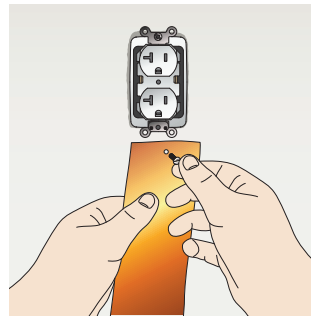

**Step 3.**

Punch small hole in 24" copper grounding strip provided with ESD flooring. The hole should be smaller than the head of the screw removed in Step 2.

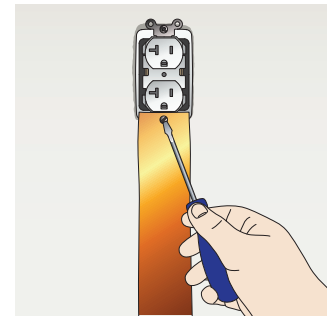

**Step 4.**

Secure copper strip to the AC electrical outlet with the same screw removed in step 2.

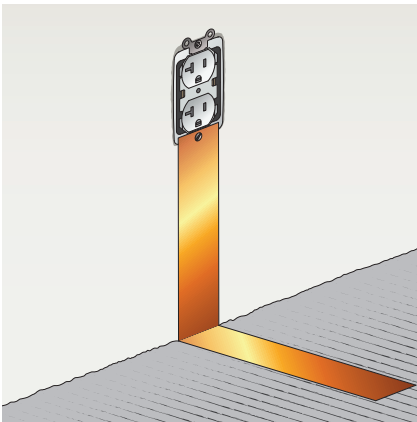

**Step 5.**

Allow 24" copper strip to run down wall to sub floor. Fold copper at 90 degree angle at point where the wall meets the floor. Lay remainder of copper strip flat on sub floor. At least 2 inches of copper should contact the floor.

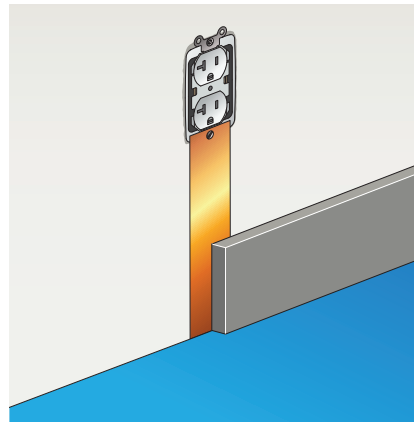

**Step 6.**

Cover copper strip on floor with conductive adhesive and new StaticWorx ESD Flooring. For a cleaner installation, copper can be covered by wall base.

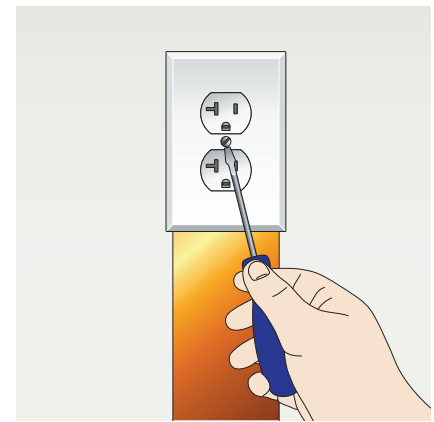

**Step 7.**

Finish installation by re-attaching AC outlet cover with screw removed in Step 1.

## METHOD 2: GROUNDING TO A NATURAL EARTH GROUND

If the floor will be installed on-grade or below grade, a copper-grounding rod can be driven into the ground creating an earth ground for the floor. The 4 to 6 ft. rod is driven into the ground until only 2 or 3 inches of the rod remains exposed from the floor. The exposed end of the copper-grounding strap is attached to the rod using a grounding clamp, usually sourced from the same manufacturer as the grounding rod (refer to [www.stormgrounding.com](http://www.stormgrounding.com).) If necessary a piece of No.10 or 12 wire can be attached to the grounding rod and run to the location of the tile grounding strap, where they are then tied together with a wire nut.

## METHOD 3: GROUNDING TO AN EARTH GROUND

If the building is constructed with exposed steel support columns, the grounding strap from the tile can be attached directly to one or more of the columns. Affix the grounding strap to the tile as described in paragraph one. Attach the opposite end of the strap directly to the support column with a grounding screw or use a grounding clamp. Drill a hole in the column and screw the grounding strap directly to the column, or mount a grounding clamp to the column and clamp the grounding strap to the column.

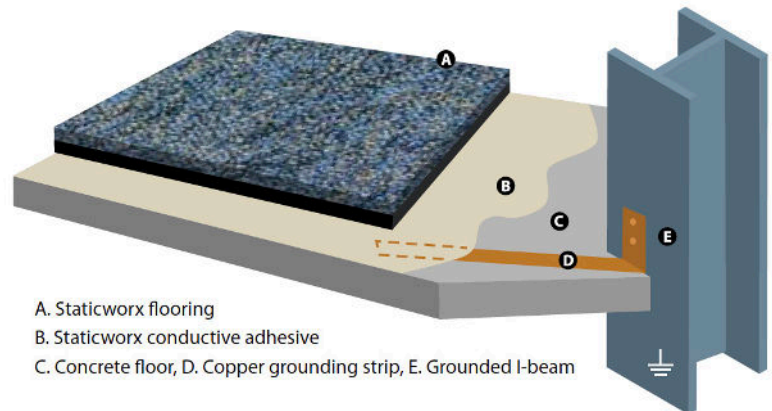

## TESTING ELECTRICAL OUTLETS

A Ground Plug Adapter is equipped with three indicating lights. The ONLY indication that is acceptable for Ground Plug Adapter use is with the two outer "CIRCUIT OK" lights energized, i.e., Lights #1 and #3 ON, Light #2 OFF.

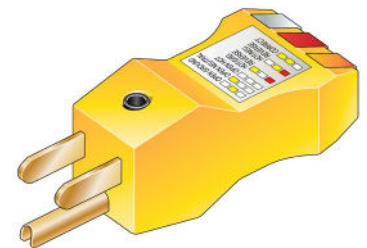

### The circuit is OK when...

#### Light #1

color: (yellow)  
condition: **ON**

#### Light #2

color: (red)  
condition: **OFF**

#### Light #3

color: (clear)  
condition: **ON**

*NOTE: If any other condition exists, do not use the receptacle or the Ground Plug Adapter until tested and approved by a qualified electrician. Examples of wiring defects are not limited to the conditions described below.*

1. OPEN GROUND WIRE – The equipment grounding conductor is not complete.
2. REVERSE POLARITY - The hot and the neutral circuit conductors are reversed.
3. OPEN HOT WIRE - The hot circuit conductor is open from a blown fuse, tripped circuit breaker, switch off, broken wire, etc.
4. OPEN NEUTRAL WIRE - The neutral circuit conductor is open.
5. HOT AND GROUND REVERSED - The hot circuit conductor and the grounding conductor are reversed.
6. HOT ON NEUTRAL AND HOT OPEN - The hot circuit conductor is connected to neutral terminal and the hot terminal is unwired.